

# TRAMPOLINES

## USER MANUAL



Before using your trampoline, it's important to carefully read all the information in this manual and retain it for further reference. Like any recreational physical activity, participants can be injured. To reduce the risk of injury, pls be sure to follow the appropriate safety rules and tips.

- Incorrect use of this trampoline can be dangerous and cause serious injury!
- When jumping on a trampoline you may reach heights and adopt positions to which you are not accustomed. Take great care and learn the required techniques.
- Always inspect the trampoline before each use.
- Assembly, maintenance, safety tips, warnings, and basic jumping techniques are covered in this manual. All users and supervisors must read and familiarize themselves with these instructions.

Initially, you should get accustomed to the feel and bounce of the trampoline. The focus must be on your body position and you should practice each fundamental bounce until you can do each skill with bounce before moving on to more difficult and advanced bounces. Do not bounce recklessly on the trampoline, emphasis must be made on good control and the mastering of various bounce techniques.

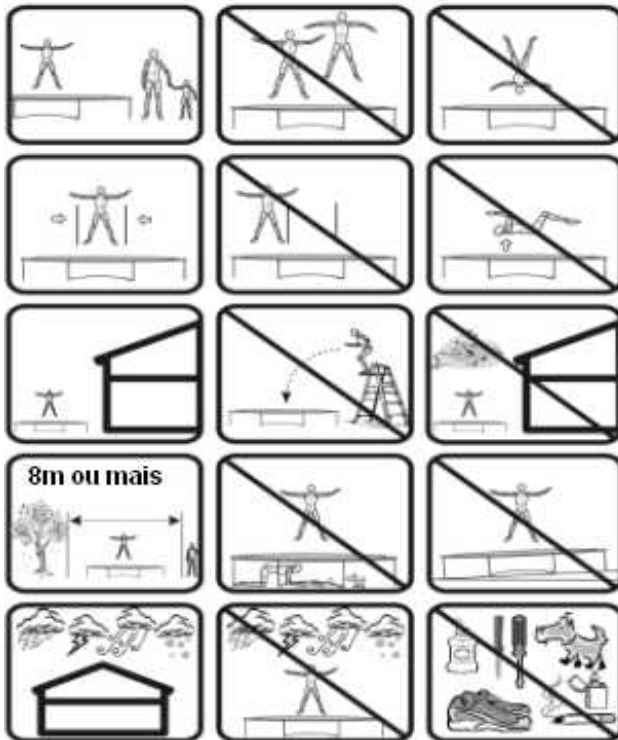

No more than one person is allowed on the trampoline at any one time!



Do not perform somersaults (flops) as these can be very dangerous for your head and neck!

# ***TRAMPOLINE GUIDELINES***

## **1. GENERAL INSTRUCTIONS**

### **1.1 PURPOSE**

- The product is intended for home/domestic use only and is not suitable for professional or medical uses.
- The maximum weight is 50kg for 8FT; 120kg for 10FT; 150kg for 12FT and 14FT. Overloading the trampoline above the recommended user weight will cause damage to the trampoline which is not covered by the warranty

### **1.2 DANGER FOR CHILDREN**

- Do not let unsupervised children near this product. Carry out the necessary safety precautions and supervise all trampoline activities. Be aware that the packaging material is not suitable for children. There is a danger of suffocation!
- Children do not recognize potential dangers from this product. Keep children away from this product, it is not a toy. The product has to be stored out of reach of children and pets.

### **1.3 ATTENTION – PRODUCT DAMAGES**

- Do not alter the product. Only use original spare parts. Repairs should only be carried out by qualified technicians. Improper repairs can compromise the safety of your trampoline. Use this product only as described in this manual
- Protect the product against humidity and high temperatures.

### **1.4 ADVICE FOR THE ASSEMBLY**

- The assembly of the product must be done carefully by at least two able-bodied adults. If in any doubt, ask a technically qualified person.
- Before you start assembling the trampoline, read all the instructions in this manual.
- Remove all packaging materials and lay down all parts on a free space. This gives you an overview and simplifies the assembly procedure.
- Check with the parts list that no parts are missing. Dispose of the packaging material when the assembly is completed
- Beware that when using tools or doing technical work, there is always a risk of injury.
- Therefore assemble the product carefully.
- Create a danger free environment, for example: do not let tools lie around the workspace.
- Store the packaging material in a way that cannot cause any danger. Foils and plastic bags are dangerous for children (danger of suffocation)!

- After installing the product according to the instruction manual, please make sure that all screws, bolts and nuts are correctly installed and tightened and that all joints are tightly fixed.
- A clearance space of at least 7.3m is necessary above the trampoline. An appropriated clearance must be kept between the trampoline and possible sources of danger, such as electric cables, tree branched, playing devices, swimming pools and fences.
- The trampoline must be set up properly before use.
- Never set up the trampoline in rainy, windy or stormy conditions, especially lighting conditions. It is recommended that the trampoline be taken apart and stored in bad weather.
- The metal frame of the trampoline will conduct electricity. Lightning, extension cords and all electrical equipment must never be allowed to come in contact with the trampoline.
- The trampoline must always be used in a well-lit area.
- Do not place any objects under the trampoline.
- The trampoline in the vicinity of other leisure devices and constructions must not be used.
- When assembling or disassembling, please use gloves to protect your hands.

## **1.5 ADDITIONAL TIPS**

- For additional stability you can place sand bags on the trampoline legs. This will prevent the trampoline from tipping over in the event of any sideways force.
- Do not use during pregnancy.
- Do not use when suffering from high blood pressure.
- Jump with bare feet. Do not wear shoes, this will damage the jumping mat which is not covered by the warranty.
- No smoking
- Do not put cigarettes, Pets, sharp objects, or any other foreign objects, or any other foreign objects on the trampolines.
- Do not use the trampoline whilst under the influence of alcohol or drugs.
- Do not sit or lean on cover pads as it needs to be flexible so it can move with the jumping mat. Please do not allow small children to pull themselves up the trampoline by using the cover pads. Tears in stitching caused by obstructing frame pads are not covered by warranty.
- Place trampoline on level ground. Preferably on grass. Locating the trampoline on hard surface will add stress to the frame and overtime cause damage which is not covered by the warranty. Placing the trampoline on uneven surfaces may result in the trampoline tipping over.
- Do not expose the trampoline to direct contact with open flames.
- Do not use if trampoline is wet.
- Trampoline should be tied down with anchors during windy conditions or dismantled and stored away.

## **WARNING**

1. Please ensure that the safety enclosure net zipper is 100% closed and all three entrance hooks are re-hooked before jumping.
2. Do not intentionally jump into the safety net, it is only designed to stop persons from falling off the trampoline. Intentional jumping into the safety net may cause the trampoline to top over, or may damage your net. Abuse of the safety net is considered negligent use which is not covered by the warranty, please refer to the disclaimer.

## **2. SAFETY INSTRUCTIONS FOR TRAMPOLINES**

- All user of the trampoline need a supervisor, regardless of the age and the experience of the user.
- The safety instructions of the trampoline should always be considered and obeyed.
- Somersaults must be avoided. Incorrect landings on the trampoline can lead to injuries, particularly to the back, neck or head. Injured may include paralysis. Or even death.
- Only one person should use the trampoline at a time. Multiple users on the trampoline will increase the risk of collision.
- The trampoline has to be examined for damaged, wearing or defective part before each usage, as it can impair the overall safety of the trampoline. The damaged, wearing or defective parts should be replaced immediately. In the meantime the trampoline must be restricted from access.
- No clothes with hooks or parts may be carried when jumping on the trampoline, in order to avoid hooks getting caught.
- The trampoline must be set up only on a flat ground and non-slippery surfaces.
- Strong wind can blow the trampoline away if strong winds are predicted. The trampoline must be moved to a protected place, and taken apart. Or fastened to the ground with cords and herrings. At least three anchorages are necessary.
- Try to avoid the moving the assembled trampoline, because it could bend during transportation. Should it be necessary to move the trampoline, please consider the following: at least four people must be evenly spaced around the frame to lift the trampoline off the ground. The trampoline must be carried horizontally, and if the frame shifts position use four people to draw the trampoline in shape.
- Trampoline are jumping devices, enabling the user to jump to unusual heights as well as into a multiplicity of body movements. Jumping into the trampoline. Hitting the frame, cover pads or incorrect landing on the trampoline can lead to injury.
- Users should be familiar with the user manual. This manual contains assembly instructions... selected precautionary measures as well as recommendations for servicing and maintenance of the trampoline. In order to ensure a secured and fun use of the trampoline.
- It is the responsibility of the owner of the supervisor to guarantee that all users of the trampoline are informed sufficient space around it as a safety precaution.
- Never use it near water and keep sufficient space around it as a safety precaution.

- Do not stick any foreign objects in to the trampoline,
- Do not allow anyone or any object to go under the trampoline while someone is jumping on the mat. The jumping mat is flexible and downwards force create by someone jumping can cause serious injury to a person.
- Implement all safety rules and make yourselves familiar with the information in the user manual
- The trampoline can be only used, if the jumping mat is clean and dry. Worn or damaged jumping mats should immediately be replaced.
- Object, which could be dangerous to the used, should be vacated from the area
- Avoid unauthorized and unsupervised use of the trampoline.
- Do not use the trampoline under influence of alcohol or drugs.
- Learn the fundamental jumping techniques thoroughly. Before trying difficult jumps. For more information. See section-fundamental bounce techniques.
- Climb on the trampoline. Do not jump on it directly. Do not use the trampoline as jump board for other articles. For more information, see section-accident categories: mounting and dismounting
- For further information or exercise documents, you can turn to a trained trampoline teacher.

## ***TRAMPOLINE PARTS LIST BOTTOM FRAME***

ITEM	MODEL	8FT-3	10FT-4	12FT-5	14FT-6
A	TOP RAIL	6	8	10	12
B	COVER PADS	1	1	1	1
C	JUMPING MAT	1	1	1	1
D	SPRINGS	42	56	70	84
E	LEG EXTENSION	/	8	10	12
F	LEG BASE	3	4	5	6
G	SCREW	/	8	10	12
H	SPRING FIXING TOOL	1	1	1	1

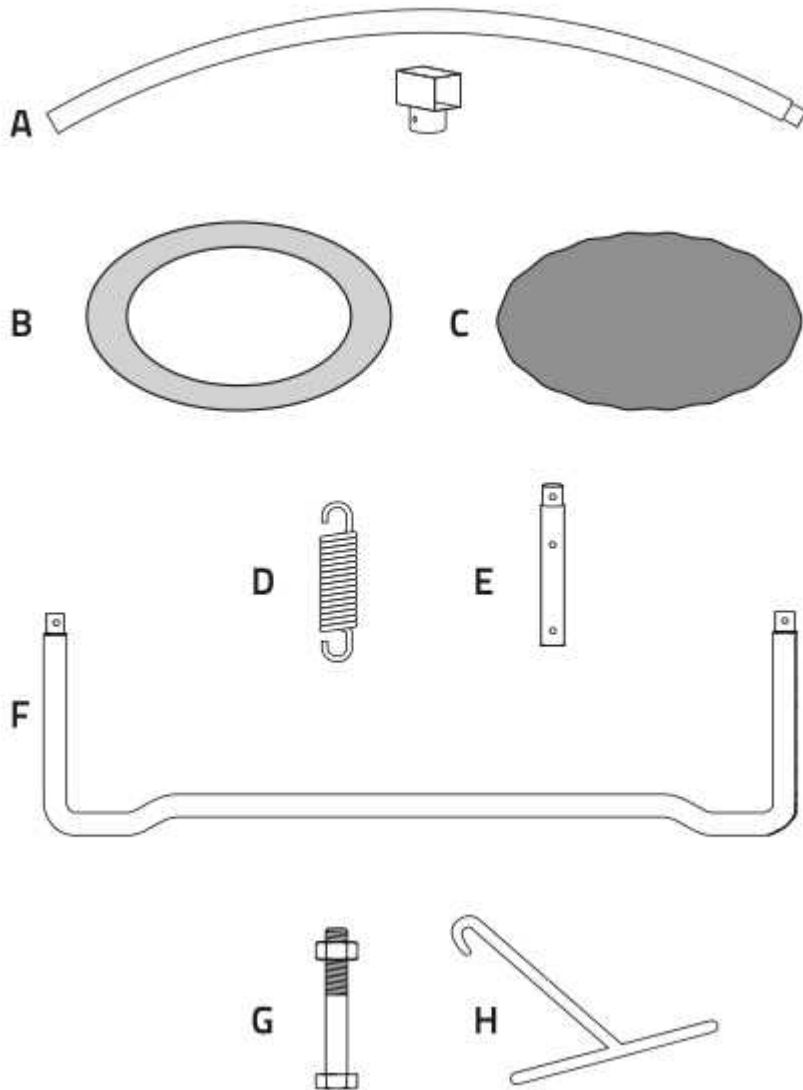

1. Take the parts out of the box and check whether the quantity is correct. Then start to assemble according to the installation drawing.

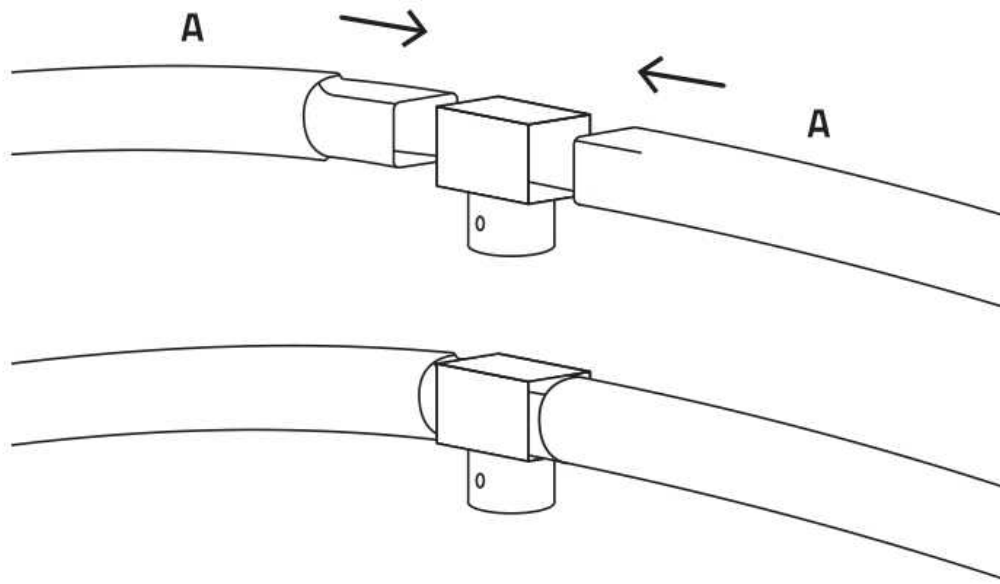

2.

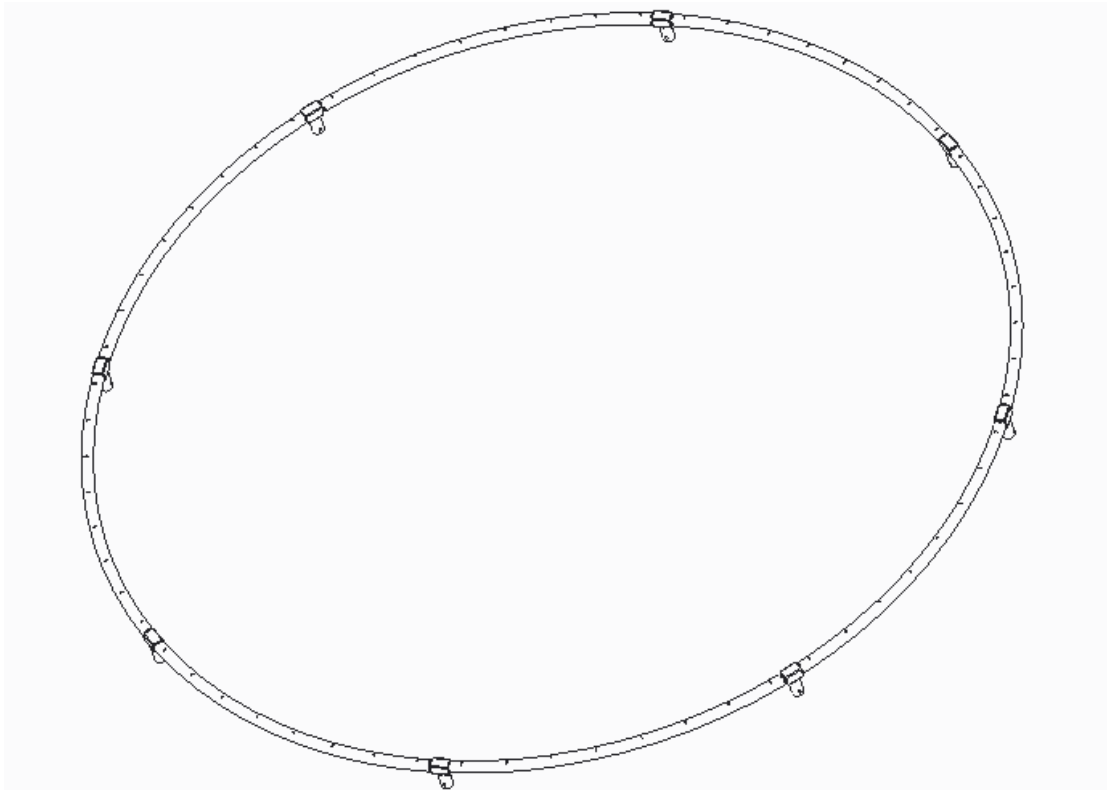



3.

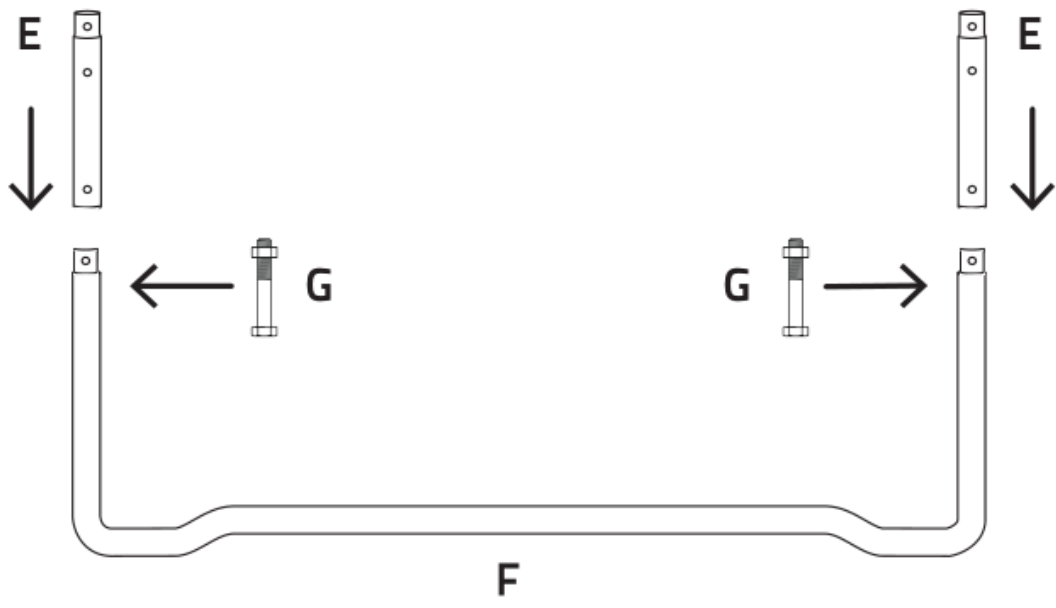

4.

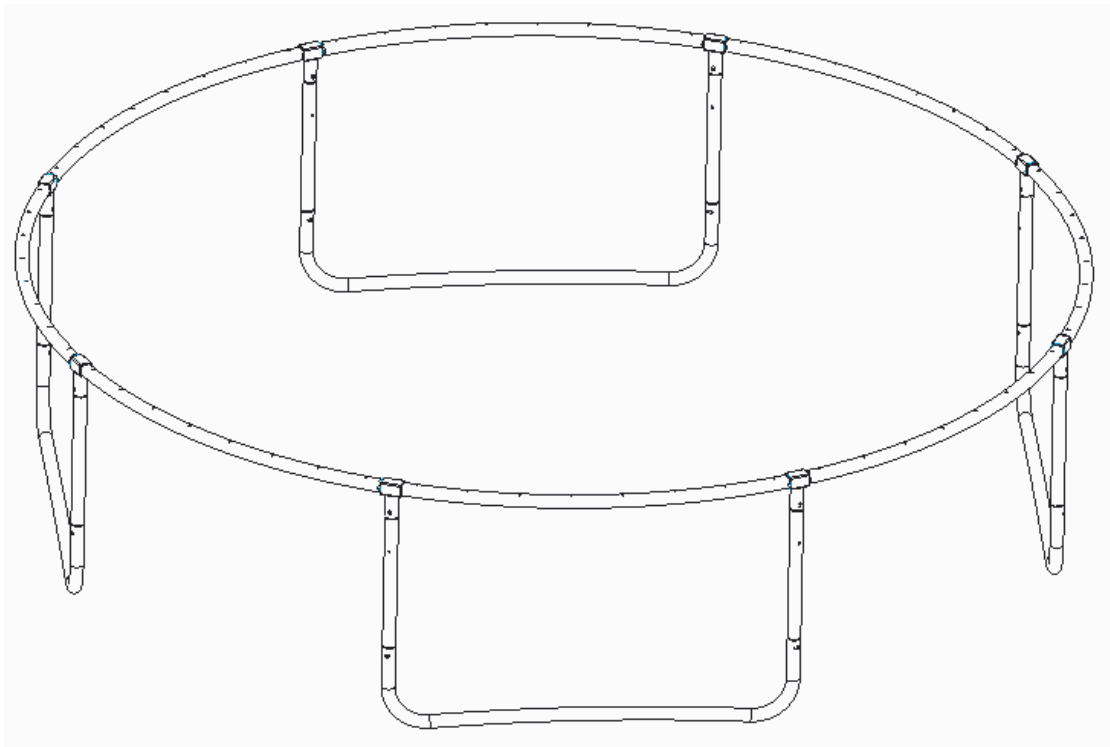

5. Position the springs opposite one another in a symmetrical fashion to avoid too much tension on one side. Between two springs attached, check that you have the same number of V-rings as holes in the frame. Then stretch the springs as shown below.

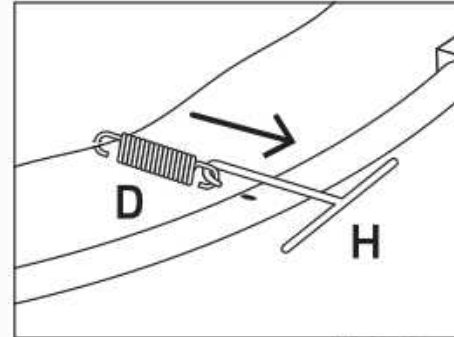
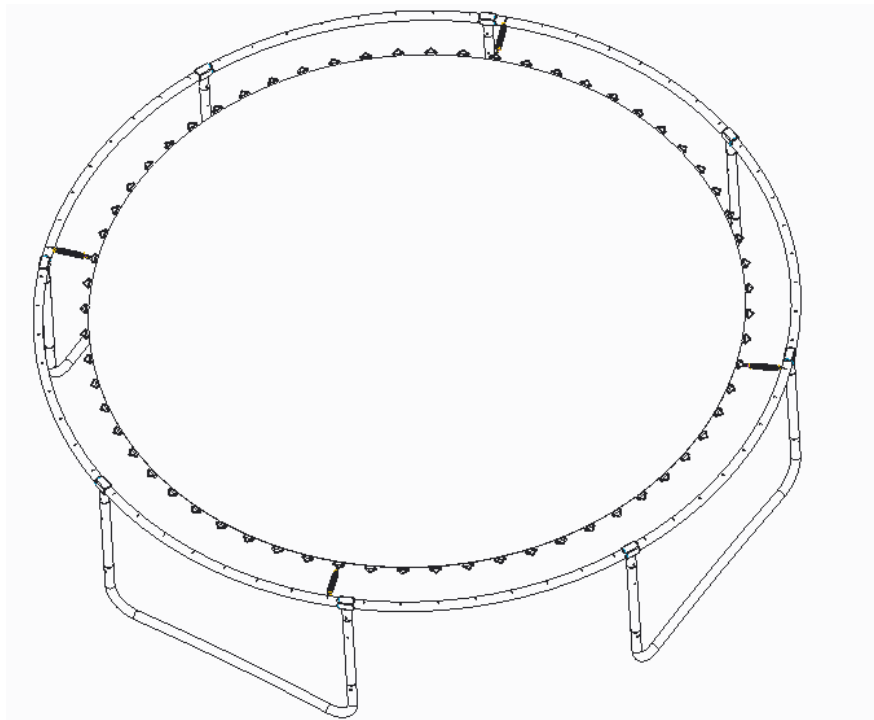

6. Install and stretch the remaining springs. Do not move the trampoline until assembly is complete.

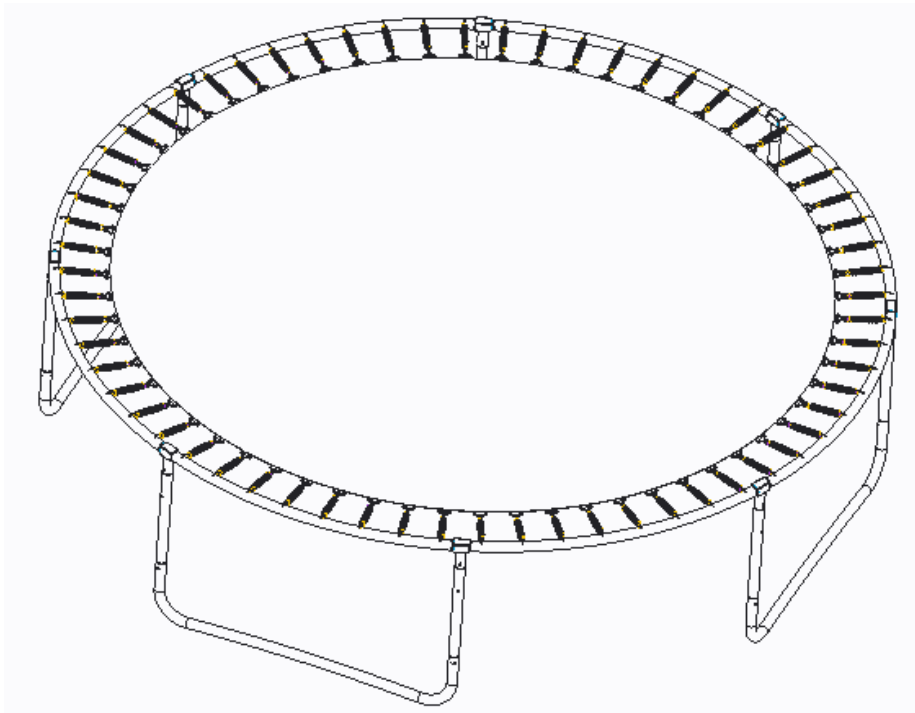

7. Cover the springs using the pad .Attach the pad to the springs using the elastic straps.

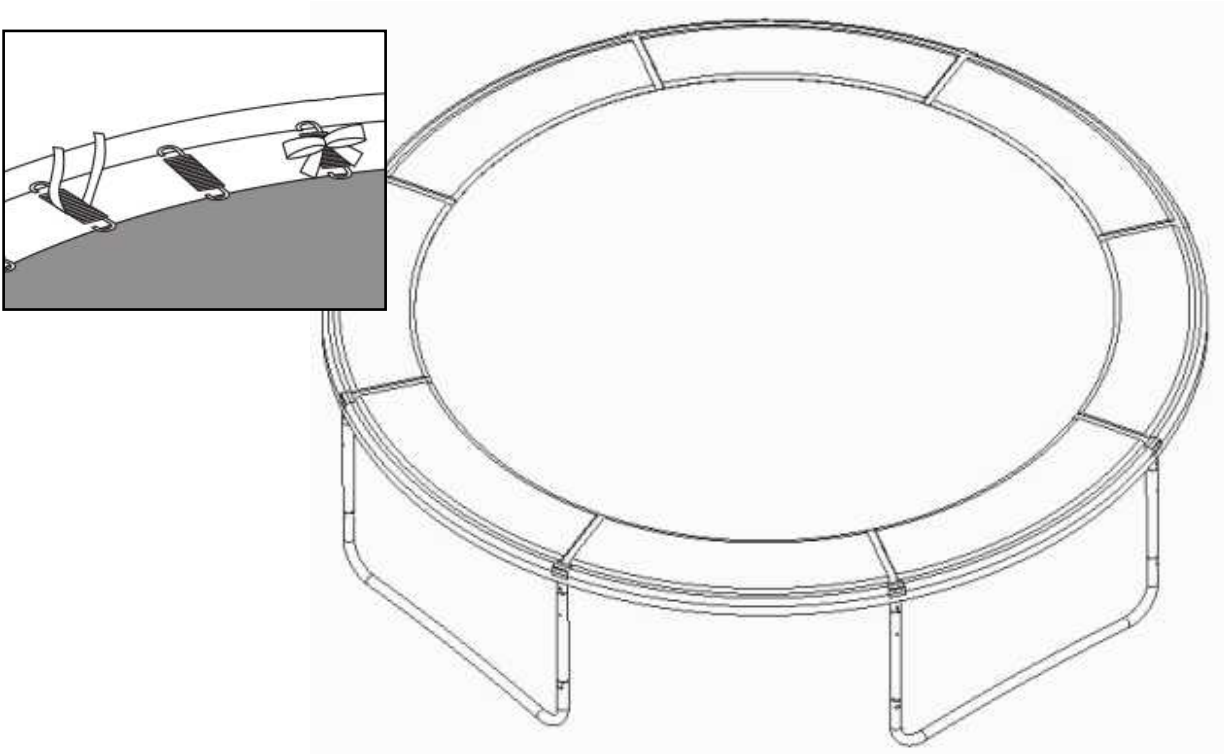

## ***ENCLOSURE PARTS LIST***

ITEM	SPARE PARTS	8FT-3	10FT-4	12FT-5	14FT-6
<b>A</b>	QUICK CLAMP	6	8	10	12
<b>B</b>	TOP FITTING	3	4	5	6
<b>C</b>	ROPE	1	1	1	1
<b>D</b>	UPPER POLE	3	4	5	6
<b>E</b>	LOWER POLE	3	4	5	6
<b>F</b>	ENCLOSURE NET	1	1	1	1
<b>G</b>	ASSEMBLY TOOL	1	1	1	1
<b>H</b>	FIBER ROD	6	8	10	12

**A**



**B**



**C**



**D**



**E**



**F**



**G**



**H**



1. Take the parts out of the box and check whether the quantity is correct. Then start to assemble according to the installation drawing.

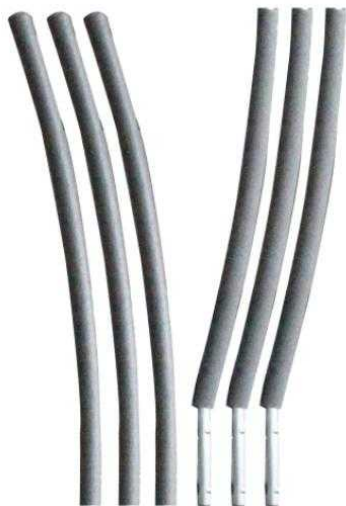
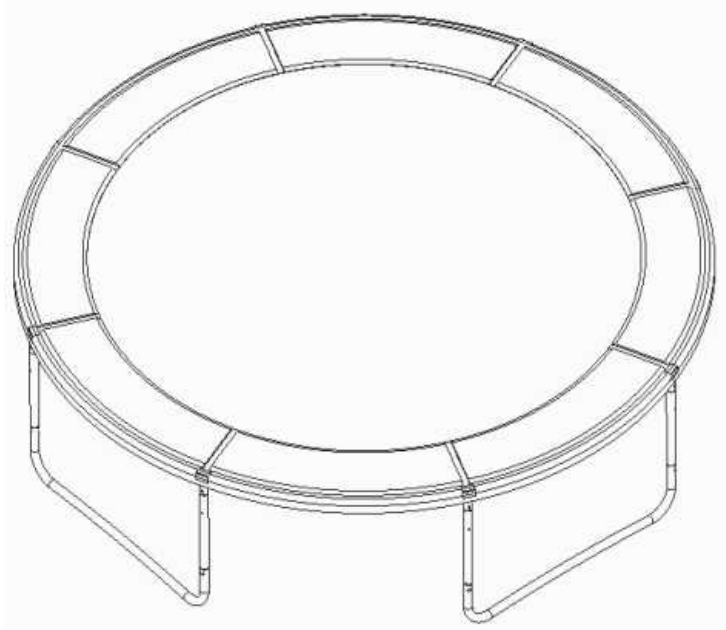

2. Attach the lower tube to the frame of trampoline using the quick clamp.

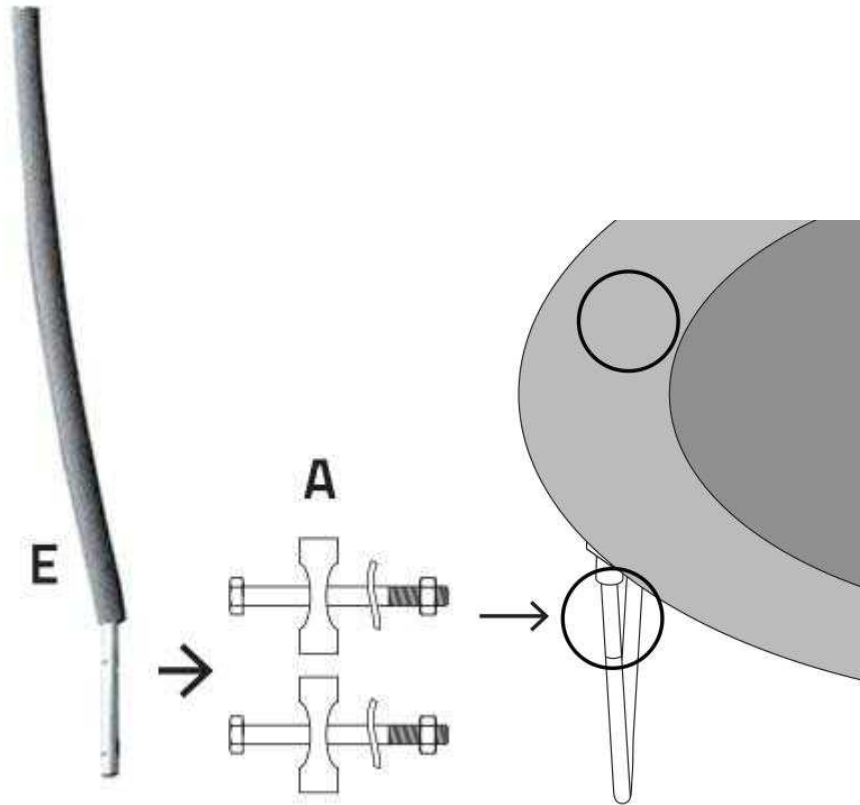

3. Once all of the lower poles have been assembled, your trampoline should look like the picture below.



4. Fit the upper pole into the lower pole.



5. Insert and assemble the different pieces of fiber rods in the upper part of the netting.  
Please follow the assembling steps and make sure that the zipper is properly placed outside.

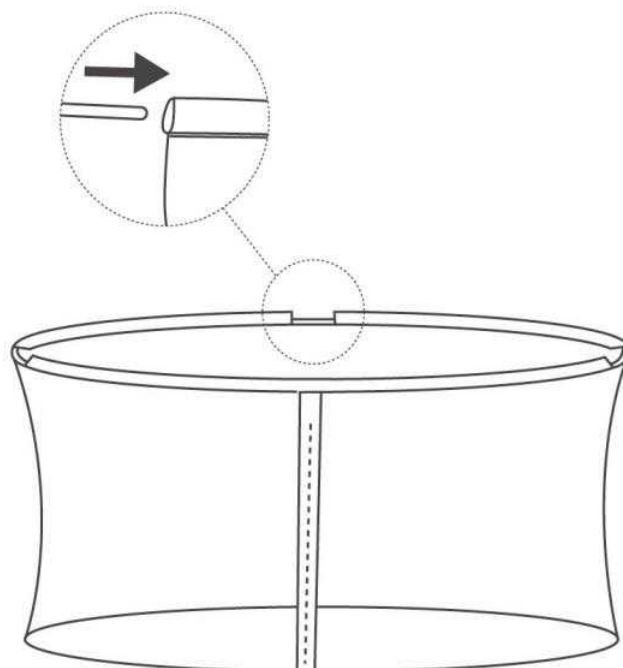

6. Assemble the TOP FITTING (netting support) as shown in the image below.

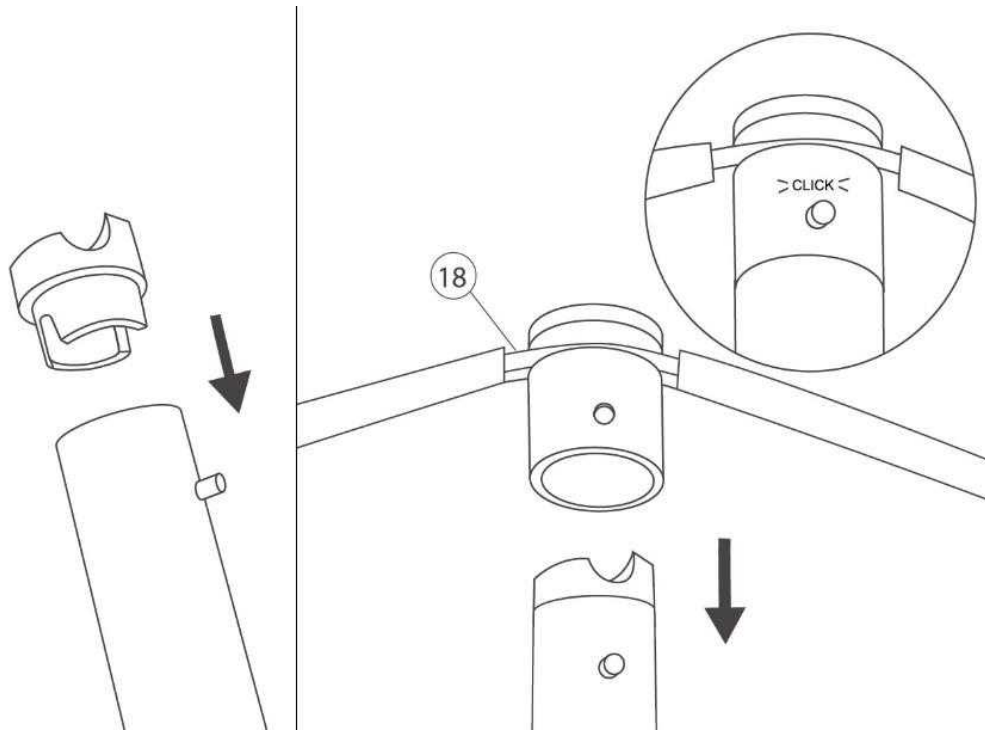

7. Use the ROPE to tie the net as shown in the image below.

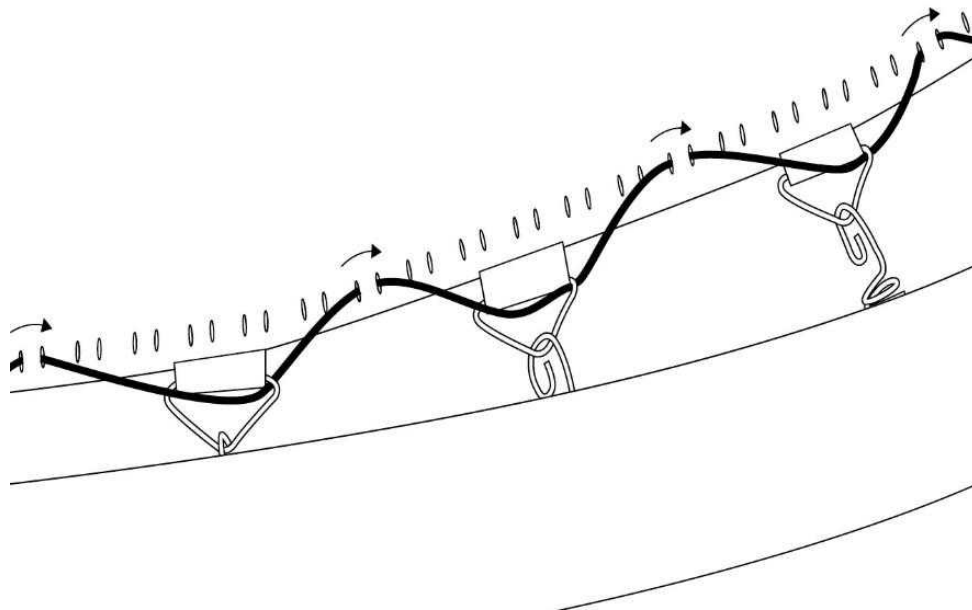



8. Check all of the fastenings on your trampoline and get several people to move it into position if necessary.



## MAINTENANCE

Although your trampoline does not require any particular maintenance a few precautions are necessary when not in use.

- The trampoline must be kept dry as much as possible. It is therefore best to cover it with a protective cover after each use or dismantle it and store it in a dry and sheltered location when not in use.
- Regularly inspect your trampoline for any defects or premature wear.
- Your trampoline was made by using an anti-rust treatment. However if traces of rust appear following prolonged exposure it is recommended to attend to these immediately with regular anti-rust treatment.
- If parts are missing or damaged, directly contact our customer service.
- When dismantling your trampoline, follow the assembly instructions above in reverse.

## BASIC TECHNIQUES

### The basic bounce

- Start in an upright position.
- Swing your arms forward in a circular motion.
- After gaining momentum, bring together the tips of

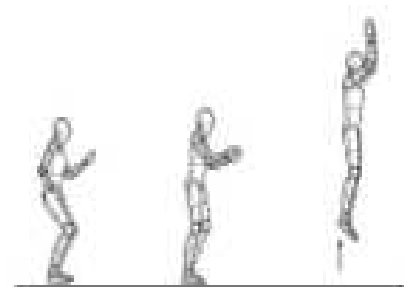

your feet pointing downwards while in the air.

### **Cushioning/slowing down**

- Users may lose their balance. The cushioning technique allows balance to be quickly regained.
- Start with a normal jump.
- When you come into contact with the mat, bend your knees to cushion the bounce.

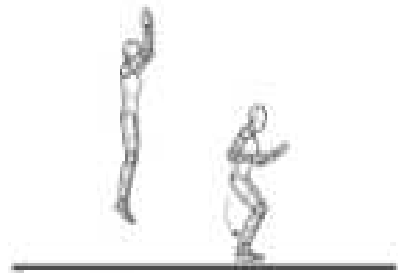

### **The hand and knee drop**

- Start with a basic bounce.
- Land on your hands and knees, with your back straight.
- Concentrate on landing evenly on the four contact points, rather than on the height of the jump.



### **Seat drop**

- Land in a seated position with your hands on the mat.
- Return to the basic position by pushing with your hands.

